



**3<sup>3</sup>/<sub>16</sub>" PORTABLE PLANER**

**MODEL G9003**

**INSTRUCTION MANUAL**



COPYRIGHT ©2000 BY GRIZZLY INDUSTRIAL, INC.  
1821 VALENCIA ST., BELLINGHAM, WA 98227

**WARNING: NO PORTION OF THIS MANUAL MAY BE REPRODUCED IN ANY SHAPE  
OR FORM WITHOUT THE WRITTEN APPROVAL OF GRIZZLY INDUSTRIAL, INC.**

APRIL, 2000 PRINTED IN U.S.A.



# **WARNING!**

**Some dust created by power sanding, sawing, grinding, drilling, and other construction activities contains chemicals known to the State of California to cause cancer, birth defects or other reproductive harm. Some examples of these chemical are:**

- **Lead from lead-based paints.**
- **Crystalline silica from bricks, cement and other masonry products.**
- **Arsenic and chromium from chemically-treated lumber.**

**Your risk from these exposures varies, depending on how often you do this type of work. To reduce your exposure to these chemicals: Work in a well ventilated area, and work with approved safety equipment, such as those dust masks that are specially designed to filter out microscopic particles.**

# SAFETY

## **WARNING**

### **For Your Own Safety Read Instruction Manual Before Operating This Equipment**

The purpose of safety symbols is to attract your attention to possible hazardous conditions. This manual uses a series of symbols and signal words which are intended to convey the level of importance of the safety messages. The progression of symbols is described below. Remember that safety messages by themselves do not eliminate danger and are not a substitute for proper accident prevention measures.



Indicates an imminently hazardous situation which, if not avoided, WILL result in death or serious injury.



Indicates a potentially hazardous situation which, if not avoided, COULD result in death or serious injury.



Indicates a potentially hazardous situation which, if not avoided, MAY result in minor or moderate injury. It may also be used to alert against unsafe practices.



This symbol is used to alert the user to useful information about proper operation of the equipment.

## **WARNING**

### **Safety Instructions For Power Tools**

- KEEP ALL SAFETY DEVICES IN PLACE** and in working order.
- REMOVE ADJUSTING KEYS AND WRENCHES.** Form habit of checking to see that keys and adjusting wrenches are removed from tool before turning on.
- KEEP WORK AREA CLEAN.** Cluttered areas and benches invite accidents.
- DON'T USE IN DANGEROUS ENVIRONMENT.** Don't use power tools in damp or wet locations, or where any flammable or noxious fumes may exist. Keep work area well lighted.
- KEEP CHILDREN AND VISITORS AWAY.** All children and visitors should be kept a safe distance from work area.
- MAKE WORK SHOP CHILD PROOF** with padlocks, master switches, or by removing starter keys.
- DON'T FORCE TOOL.** It will do the job better and safer at the rate for which it was designed.
- USE RIGHT TOOL.** Don't force tool or attachment to do a job for which it was not designed.

# WARNING

## Safety Instructions For Power Tools

- 9. USE PROPER EXTENSION CORD** for the tool. Make sure your extension cord is in good condition. Conductor size should be in accordance with the chart below. The amperage rating should be listed on the motor or tool nameplate. An undersized cord will cause a drop in line voltage resulting in loss of power and overheating. Your extension cord must also contain a ground wire and plug pin. Always repair or replace extension cords if they become damaged.

Minimum Gauge for Extension Cords

AMP RATING	LENGTH		
	25ft	50ft	100ft
0-6	18	16	16
7-10	18	16	14
11-12	16	16	14
13-16	14	12	12
17-20	12	12	10
21-30	10	10	No

- 10. WEAR PROPER APPAREL.** Do not wear loose clothing, gloves, neckties, rings, bracelets, or other jewelry which may get caught in moving parts. Non-slip footwear is recommended. Wear protective hair covering to contain long hair.
- 11. ALWAYS USE SAFETY GLASSES.** Also use face or dust mask if cutting operation is dusty. Everyday eyeglasses only have impact resistant lenses, they are NOT safety glasses.
- 12. SECURE WORK.** Use clamps or a vise to hold work when practical. It's safer than using your hand and frees both hands to operate tool.

- 13. DON'T OVERREACH.** Keep proper footing and balance at all times.
- 14. MAINTAIN TOOLS WITH CARE.** Keep tools sharp and clean for best and safest performance. Follow instructions for lubricating and changing accessories.
- 15. DISCONNECT TOOLS** before servicing and changing accessories, such as blades, bits, cutters, and the like.
- 16. REDUCE THE RISK OF UNINTENTIONAL STARTING.** Make sure switch is in off position before plugging in.
- 17. USE RECOMMENDED ACCESSORIES.** Consult the owner's manual for recommended accessories. The use of improper accessories may cause risk of injury.
- 18. CHECK DAMAGED PARTS.** Before further use of the tool, a guard or other part that is damaged should be carefully checked to determine that it will operate properly and perform its intended function. Check for alignment of moving parts, binding of moving parts, breakage of parts, mounting, and any other conditions that may affect its operation. A guard or other part that is damaged should be properly repaired or replaced.
- 19. NEVER LEAVE TOOL RUNNING UNATTENDED. TURN POWER OFF.** Don't leave tool until it comes to a complete stop.

# **WARNING**

## **Safety Instructions For Portable Planers**

- 1. USE ONLY FOR WOOD.** This machine is not designed to process any material other than wood.
- 2. ALWAYS KEEP FINGERS AND HANDS AWAY FROM ROTATING CUTTERHEAD.** Never attempt to clear chips away from the base of the chip chute when the machine is running. Stop the machine, unplug it, then clear away the debris.
- 3. NEVER OPERATE WITH DULL OR DAMAGED BLADES.** Check blades frequently for sharpness or damage. Damaged or dull blades put excessive strain on the machine and can cause loss of control of the unit.
- 4. ENSURE PLANER IS PROPERLY ADJUSTED BEFORE STARTING.** Always use a test piece to check the adjustment and operation before starting on the actual workpiece.
- 5. DO NOT REMOVE EXCESSIVE AMOUNTS OF WOOD IN A SINGLE PASS.** Better results can be achieved by taking multiple passes with a small amount of material removal in each pass.
- 6. INSPECT STOCK THOROUGHLY BEFORE PLANING.** Look stock over for any grit, sand, nails, staples or other foreign materials before performing planing operations. Foreign materials can damage the blade and can throw off debris which may cause injury.
- 7. MAKE SURE WORKPIECE IS SECURELY CLAMPED OR OTHERWISE HELD IN PLACE.** Also make sure the clamps will not obstruct the movement of the Planer as it progresses through the cut. Hitting an unexpected obstruction can cause potential loss of control of the machine.

# CONTROL LOCATION

## Control Location

Refer to **Figure 1** for the location of the key components and controls of this Planer. Become familiar with the controls and the adjustments before operating the Planer.

## Specifications

Speed: 15000 RPM

Motor Type: Universal Brush Motor

Motor Power: ½ HP, 110V, 5.0 Amp

Cutterhead: 2 Blades

Maximum Cutting Width: 3<sup>3</sup>/<sub>16</sub>"

Maximum Stock Removal/Pass: 1/32"

Maximum Rabbet Depth: 1<sup>1</sup>/<sub>32</sub>"

Weight: 5.75 lbs

Accessories Included: Fence, Blade Removal Wrench, Sharpening Jig, Blade Setting Jig, Replacement Belt and Replacement Motor Brushes

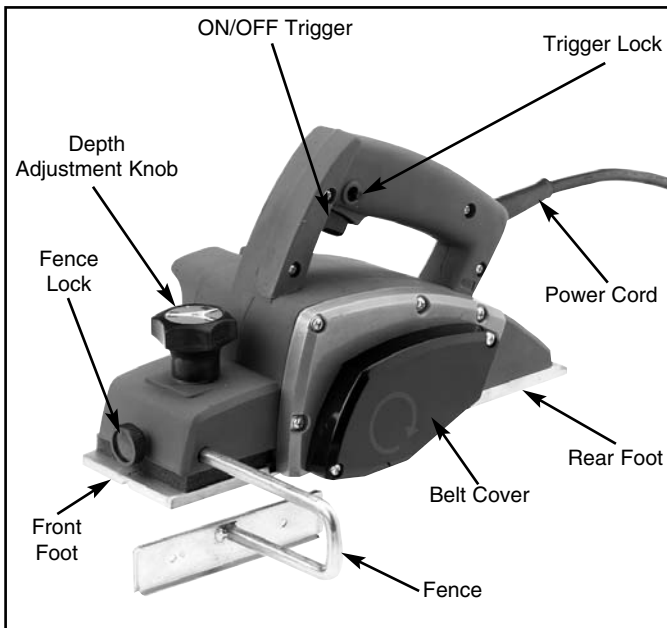

**Fig 1.** Location of controls.

# BLADE ADJUSTMENT & REMOVAL

## CAUTION

Turn the switch off and unplug the Planer from power before attempting blade removal or any adjustments. Serious injury may occur if the unit should be accidentally started while checking or removing the blades.

The Planer comes with the blades already installed. Check the blades before the first use to make sure they are set properly.

### To Check Blade Height Setting:

1. Lay a straightedge across the Rear Foot and the Cutterhead. Do not position the straightedge so it contacts the Front Foot. See **Figure 2**.



**Figure 2.** Checking Blade height.

2. Rotate the Cutterhead manually with the exposed portion of the belt (right next to the Cutterhead). The tip of the blade at its highest point should just barely touch the straightedge. Move the straightedge back and forth across the width of the blade to make sure

the amount of contact is the same all the way across.

3. If there is too much contact, or none at all, at any point across the blade, then the blade needs to be reset. Refer to Blade Installation Section.
4. Repeat procedure for the other Blade.

### To Remove the Blade Assemblies:

1. Using the belt pulley, rotate the Cutterhead so that one of the two Blade Holders is positioned in the opening in the base.
2. Use the supplied T-handle wrench to remove the three hex head bolts holding the Blade Assemblies to the Cutterhead. Hold the Cutterhead in position with the Belt Pulley. See **Figure 3**.

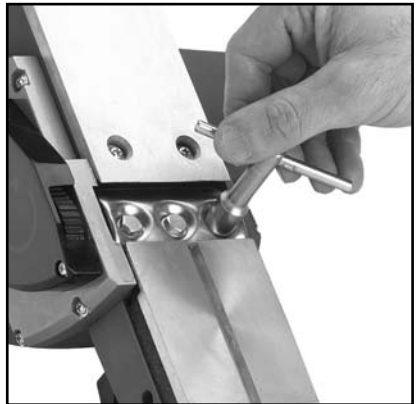

**Figure 3.** Removing Blade Holder bolts.

3. Lift the Blade Holder and Blade Assembly off, being careful to not come in contact with the sharp edge of the blade.
4. Repeat procedure for the other Blade.

# BLADE INSTALLATION

## CAUTION

Turn the switch off and unplug the Planer from power before attempting blade installation or any adjustments. Serious injury may occur if the unit should be accidentally started while installing the blade.

The Blade must be mounted to the Back Plate using the Blade Setting Jig. Using this jig controls how far the blade extends from the Cutterhead once it is installed.

1. Place the Blade onto the Setting Jig.
2. Lay the Back Plate onto the top of the Blade, pushing it up firmly against the edge of the Jig. See **Figure 4**.

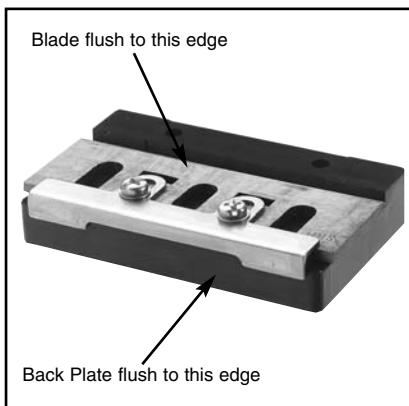

**Fig 4.** Blade in position on Setting Jig.

3. Install two Phillips® head screws with washer and lockwasher through the slots on the Back Plate into the Blade. Tighten securely.

4. Set the Blade/Back Plate Assembly onto the Cutterhead. Make sure the bottom edge of the Back Plate is positioned into the slot on the Cutterhead. See **Figure 5**.

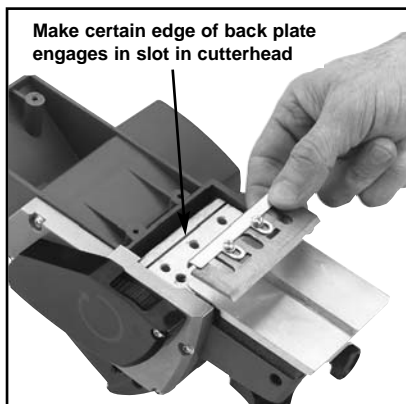

**Fig 5.** Inserting blade assembly on Cutterhead (Rear Foot removed for clarity).

5. Set the Blade Holder over the Blade Assembly so the notches in the side of the Holder engage the rear edge of the blade. Install three hex head bolts and washers, and tighten with the supplied T-handle wrench.
6. Repeat the procedure for the other blade.

## CAUTION

Never operate the Planer with only one blade installed. This will cause an imbalance of the rotating cutterhead and may allow the Planer to go out of control, possibly causing injury.



# BLADE SHARPENING

The Blade must be completely removed from the Planer and from the Back Plate in order for it to be safely sharpened. Follow the preceding instructions for Blade Removal.

For the best results, have planer blades sharpened by a professional sharpening service which has the grinding and measurement equipment to assure that the blade cutting geometry is maintained at optimum levels. It is a procedure which requires special equipment and precision, otherwise, a set of blades can be easily ruined. Knives should always be ground as a set so that an equal amount of material is removed which will maintain the balance of the cutterhead.

The blades can be tuned up between major sharpenings using the Sharpening Jig supplied. Remove both Blades completely from the Planer.

## To Sharpen Blades:

1. Separate the Blade from the Back Plate by removing two Phillips® head screws.
2. Mount the two Blades onto the Sharpening Jig as shown in **Figure 6**.

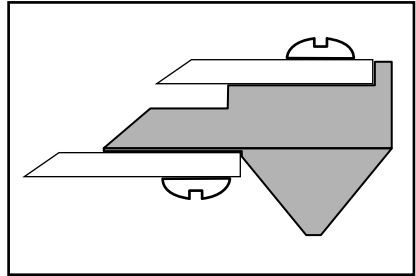

**Fig 6.** Blades in Sharpening Jig.

3. The bevel edge of the blades will extend beyond the sloped edge of the Jig. The blades can be sharpened by sweeping a fine metal file along the two edges, using the existing bevel angle as a guide. Or the entire Jig can be turned face down on a sharpening stone and swept across the surface of the stone.
4. Remove the Blades from the Jig and reinstall into the Planer.

Blade sharpness is one of the most important factors in getting good results with the planer. Take care to ensure that the workpiece being planed is free from grit, dirt, or nails or other embedded metals such as staples. These can nick or chip the knives and can require a complete regrinding.

## CAUTION

Planer blades are dangerously sharp. Use extreme caution when inspecting, removing, sharpening, or replacing blades into the cutterhead. Substantial risk of laceration injury exists!

# OPERATIONS

---

## Setting Cutting Depth

Lay a straightedge across the Rear Foot and extend it across the Front Foot. Rotate the cutterhead so neither of the blades are touching the straightedge. Turn the Depth Adjustment Knob until the Front and Rear plates are at the same height (the straight-edge will contact both feet evenly). This is a "0" depth of cut. Note the position of the "0" point on the knob scale. Three-quarters of a full rotation of the knob is equivalent to a  $\frac{1}{32}$ " depth of cut, the maximum depth of cut recommended. Generally the best results will be achieved with several successive passes rather than trying to remove the maximum amount of material in one pass.

## Planing

The most common operation is to plane the edge of a board to get a straight, square edge. A Portable Planer is also useful when an uneven edge is required, such as when fitting a countertop to a wall. The Planer can be used to cut right down to a scribe line by taking selective cuts.

This Planer can also be used for face planing, that is, to clean up the rough surface of a board. This is most easily accomplished on boards which are less than  $3\frac{3}{16}$ " wide where the planing can be done in a single pass. Success in face planing will be best when very light passes are made.

### To Perform Planing Operations:

1. Secure the workpiece firmly with clamps so it will not move during the planing process.
2. Set the desired depth of cut.

3. Turn the Planer on by pulling the ON/OFF trigger. Allow the cutterhead to achieve full speed before engaging the workpiece.
4. Once the cutting begins, push the Planer firmly across the workpiece at the same rate of speed. Do not stop the Planer's progress across the piece during the pass. Do not apply downward pressure, use the handle to apply force to push the Planer along.
5. Check the edge for straightness and squareness, or for the desired profile, as successive passes are made.

## WARNING

**Operating this equipment has the potential to propel debris into the air which can cause eye injury. Always wear safety glasses or goggles when operating equipment. Be certain the safety glasses you wear meet the appropriate standards of the American National Standards Institute (ANSI).**

# OPERATIONS

## Chamfering

The Front Foot has a V-groove machined into it to allow for edge chamfering. Position the Planer on the corner of the workpiece, with the V-groove seated on the corner. **See Figure 7.** Be sure the workpiece is firmly secured with clamps or other holding devices.

Start the Planer and let it get to full speed before moving the Cutterhead into the workpiece. Apply steady, even pressure and keep the Planer moving along the edge. The Rear Foot will sit on the Chamfered edge as it comes out of the cutter. Support the Planer so it does not slip off of the edge.



Fig 7. Cutting a chamfer.

## Rabbeting

Rabbeting is the cutting of a notch along the edge of a board to allow mating pieces to fit together tightly. The Planer can be used to cut rabbets by using the supplied fence and setting it so that only the necessary amount of the cutterhead will actually cut into the workpiece. It will take several

successive passes to achieve the full depth of the rabbet as the maximum depth of cut is  $\frac{1}{32}$ " per pass. The maximum rabbet depth is  $\frac{1}{32}$ ". **See Figure 8.**

### To Perform Rabbeting Operations:

1. Secure the workpiece firmly with clamps to eliminate movement during the planing operation.
2. Install the fence guide by inserting it into the hole in the left front of the planer body and tightening the holding knob at the front of the planer.
3. Set the fence distance so that the cutter cuts into the workpiece by the desired width. Test on a sample piece and check dimension.
4. Set the desired depth of cut with the Adjustment Knob. Generally it is best to take shallow cuts per pass to avoid chipping.
5. Start the Planer. Let the cutterhead get up to full speed before engaging the cutter into the work.
6. Take successive passes until the full depth is achieved.

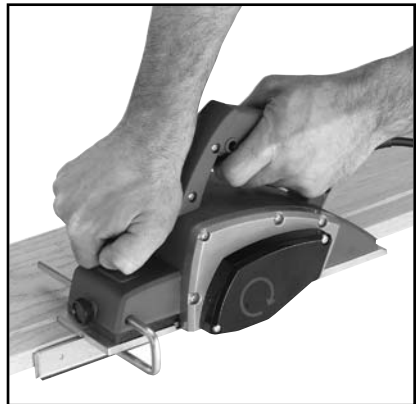

Fig 8. Cutting a rabbet.

# MAINTENANCE

## Maintenance

Your 110 V Portable Planer will give you hundreds of hours of operation time before ever needing service. This product is double insulated which provides protection from electrical shock should a problem ever develop with grounding. Great care must be taken whenever servicing double insulated equipment to make certain the repair does not destroy the insulated properties. Service should be performed only by a qualified electrical technician.

## Belt Replacement

Refer to the Troubleshooting guide for typical symptoms of a worn belt.

### To Replace the Belt:

1. Remove the belt cover.
2. Remove broken or worn belt.
3. Work the new belt onto the pulleys. It will be necessary to push down on the edge of the belt while manually turning the pulleys. **See Figure 9.**
4. Replace the belt cover.



Fig 9. Replacing belt.

## Brush Replacement

The universal motor has two brushes which may periodically need replacement. When checking or replacing the brushes, make sure the slots the brushes fit into are clear of grit or debris so the brushes are free to move in and out.

### To Replace The Brushes:

1. Remove the motor cover by removing the two screws on the housing.
2. Remove the brush caps with a large flat bladed screwdriver. **See Figure 10.**
3. Pull the brush out. The end has a metal disc which is attached to a spring-like piece. If the slot has foreign material in it, the brush may be hard to remove.
4. Clear the brush slot with a screwdriver and make sure it is free of grit. Insert the new brush, check to make sure it goes into the slot and comes out against the commutator.
5. Replace the brush cover.
6. Repeat for the other brush.
7. Replace the motor cover.



Fig 10. Replacing motor brushes.

# OPERATING TIPS

---

## Operating Guides and Tips

**Avoid overloading the planer.** Do not apply downward pressure to the tool while using. Do not feed into the work so rapidly that it causes the motor to bog down.

### **Ensure the safety of the workplace.**

Clear the work area of all parts and debris that may cause injury by flying objects. Securely fix the object to be worked on in a vise or otherwise clamp to avoid injury. Do not attempt to hold workpiece by hand.

### **Inspect the tool before use.**

Run the tool free of the workpiece before using to ensure all parts are running smoothly and there are no abnormal sounds or sparks. If any defect is found, have unit serviced.

## **WARNING**

Operating this equipment has the potential to propel debris into the air which can cause eye injury. Always wear safety glasses or goggles when operating equipment. Be certain the safety glasses you wear meet the appropriate standards of the American National Standards Institute (ANSI).

## **WARNING**

Disassembly and improper reassembly of this device can result in electrical shock danger. Always have this device serviced by a qualified electrical repair technician. Serious injury will result.

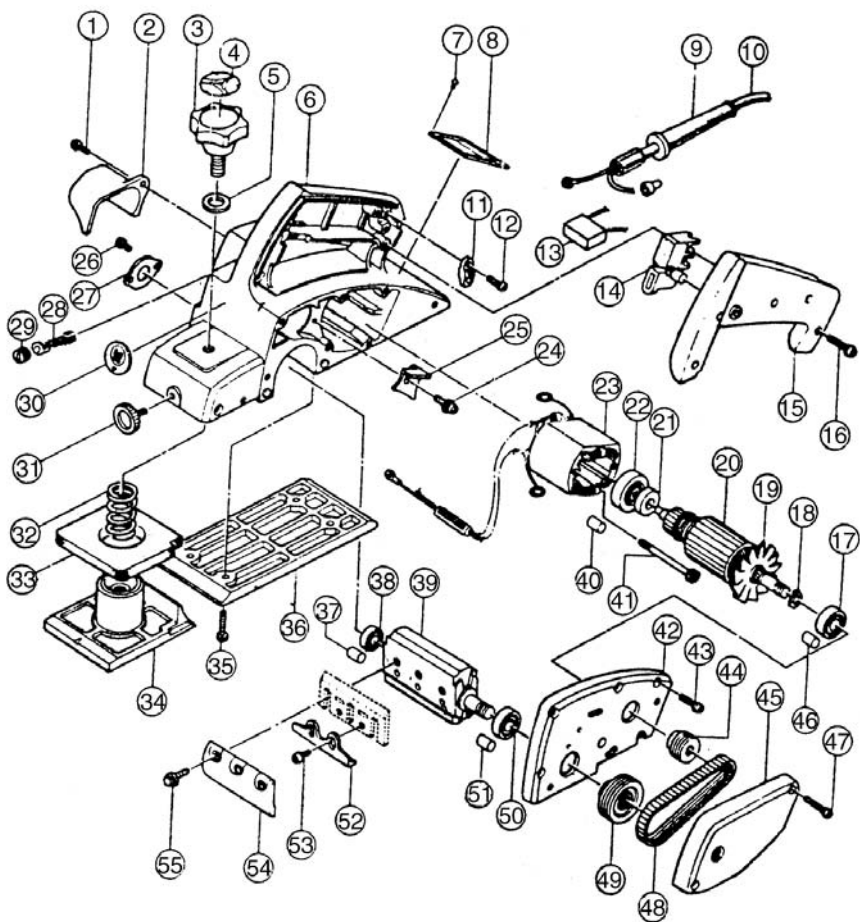

Ref. #	Part #	Description
001	P9003001	Pan Hd Screw M4 x 16
002	P9003002	Chip Cover
003	P9003003	Knob
004	P9003004	Scale Plate for Knob
005	P9003005	Flat Washer 10mm
006	P9003006	Main Frame
007	P9003007	Rivet
008	P9003008	Name Plate
009	P9003009	Cord Guard
010	P9003010	Cord
011	P9003011	Strain Relief
012	P9003012	Pan Hd Screw M4 x 18
013	P9003013	Noise Suppressor
014	P9003014	Switch
015	P9003015	Handle Cover
016	P9003016	Pan Hd Screw M4 x 25
017	P9003017	Bearing (6000LL8)
018	P9003018	Stop Ring E-9
019	P9003019	Fan
020	P9003020	Armature Assy (w/17&22)
021	P9003021	Insulation Washer
022	P9003022	Bearing (627LB)
023	P9003023	Field Assembly
024	P9003024	Pan Hd Screw M4 x 16
025	P9003025	Auxiliary Baffle Plate
026	P9003026	Pan Hd Screw M4 x 10
027	P9003027	Bearing Cover
028	P9003028	Carbon Brush

Ref. #	Part #	Description
029	P9003029	Brush Holder Cap
030	P9003030	Indication Plate
031	P9003031	Screw M5 x 10
032	P9003032	Compression Spring
033	P9003033	Rubber Packing
034	P9003034	Front Base
035	P9003035	Pan Hd Screw M5 x 18
036	P9003036	Base
037	P9003037	Rubber Pin
038	P9003038	Bearing (608ZZ)
039	P9003039	Drum
040	P9003040	Rubber Pin
041	P9003041	Hex Hd Bolt M4 x 20
042	P9003042	Bracket
043	P9003043	Pan Hd Screw M4 x 20
044	P9003044	V-Pulley 4-20L
045	P9003045	Belt Cover
046	P9003046	Rubber Pin
047	P9003047	Pan Hd Screw M4 x 25
048	P9003048	Poly V-Belt 4-24L
049	P9003049	V-Pulley 4-37
050	P9003050	Bearing (6000ZZ)
051	P9003051	Ruber Pin
052	P9003052	Adjustment Plate
053	P9003053	Pan Hd Screw M4 x 5
054	P9003054	Drum Plate
055	P9003055	Hex Hd Flange Bolt M6 x 17

# TROUBLESHOOTING

SYMPTOM	POSSIBLE CAUSE	CORRECTIVE ACTION
Motor will not start.	<ol style="list-style-type: none"> <li>1. Low voltage.</li> <li>2. Brushes worn or sticking.</li> <li>3. Open circuit in motor or loose connections.</li> </ol>	<ol style="list-style-type: none"> <li>1. Check power line for proper voltage.</li> <li>2. Replace both brushes.</li> <li>3. Inspect by qualified electrical technician.</li> </ol>
Motor will not start; fuses or circuit breakers blow.	<ol style="list-style-type: none"> <li>1. Short circuit in line cord or plug.</li> <li>2. Short circuit in motor or loose connections.</li> </ol>	<ol style="list-style-type: none"> <li>1. Inspect cord or plug for damaged insulation and shorted wires.</li> <li>2. Inspect by qualified electrical technician.</li> </ol>
Motor overheats.	<ol style="list-style-type: none"> <li>1. Motor overloaded.</li> <li>2. Air circulation through the motor restricted.</li> </ol>	<ol style="list-style-type: none"> <li>1. Reduce load on motor.</li> <li>2. Clean out motor vents</li> </ol>
Motor arcing visibly through vents or runs erratically.	<ol style="list-style-type: none"> <li>1. Brushes sticking.</li> <li>2. Brushes worn.</li> </ol>	<ol style="list-style-type: none"> <li>1. Check that brush holder is free of dirt and that brush moves freely.</li> <li>2. Replace both brushes.</li> </ol>
Machine slows when operating.	<ol style="list-style-type: none"> <li>1. Feed rate too high.</li> <li>2. Depth of cut too great.</li> <li>3. Brushes worn.</li> </ol>	<ol style="list-style-type: none"> <li>1. Feed planer slower.</li> <li>2. Reduce depth of cut.</li> <li>3. Replace both brushes.</li> </ol>
Machine is loud when cutting. Overheats or bogs down in the cut.	<ol style="list-style-type: none"> <li>1. Excessive depth of cut.</li> <li>2. Blades are dull</li> <li>3. Blade holder or blade assembly mounting is loose.</li> <li>4. Belt is worn or loose.</li> <li>5. Short circuit in motor.</li> </ol>	<ol style="list-style-type: none"> <li>1. Decrease depth of cut.</li> <li>2. Sharpen blades.</li> <li>3. Recheck complete blade installation and tighten all screws.</li> <li>4. Replace belt.</li> <li>5. Inspect by qualified electrical technician.</li> </ol>
Planer starts, but cutter-head does not move.	Worn or broken belt	Replace belt
Planer starts, cutter-head turns, no cut.	<ol style="list-style-type: none"> <li>1. Blade not extending below foot.</li> <li>2. Belt worn or slipping.</li> </ol>	<ol style="list-style-type: none"> <li>1. Increase depth of cut.</li> <li>2. Replace belt.</li> </ol>
Rough or fuzzy cut.	<ol style="list-style-type: none"> <li>1. Blades are dull.</li> <li>2. Excessive depth of cut.</li> <li>3. Cutting against natural wood grain.</li> <li>4. High wood moisture content.</li> </ol>	<ol style="list-style-type: none"> <li>1. Sharpen blades.</li> <li>2. Decrease depth of cut.</li> <li>3. Reverse cutting direction.</li> <li>4. Dry wood.</li> </ol>
Cut not smooth or straight.	Blade not flush with rear foot.	Reset blades in jig.



# WARRANTY CARD

Name \_\_\_\_\_

Street \_\_\_\_\_

City \_\_\_\_\_ State \_\_\_\_\_ Zip \_\_\_\_\_

Phone Number \_\_\_\_\_ E-Mail \_\_\_\_\_ FAX \_\_\_\_\_

MODEL # G9003 Portable Planer Order # \_\_\_\_\_

The following information is given on a voluntary basis. It will be used for marketing purposes to help us develop better products and services. Of course, all information is strictly confidential.

- How did you learn about us?  
 Advertisement  Friend  
 Catalog  Card Deck  
 World Wide Web  
 Other \_\_\_\_\_
- What is your annual household income?  
 \$20,000-\$29,999  \$60,000-\$69,999  
 \$30,000-\$39,999  \$70,000-\$79,999  
 \$40,000-\$49,999  \$80,000-\$89,999  
 \$50,000-\$59,999  \$90,000 +
- What is your age group?  
 20-29  50-59  
 30-39  60-69  
 40-49  70 +
- How long have you been a woodworker?  
 0 - 2 Years  8 - 20 Years  
 2 - 8 Years  20+ Years
- How would you rank your woodworking skills?  
 Simple  Advanced  
 Intermediate  Master Craftsman
- What stationary woodworking tools do you own?  
Check all that apply.  
 Air Compressor  Panel Saw  
 Band Saw  Planer  
 Drill Press  Power Feeder  
 Drum Sander  Radial Arm Saw  
 Dust Collector  Shaper  
 Spindle Sander  Jointer  
 Table Saw  Lathe  
 Mortiser  Wide Belt Sander  
 Horiz.Boring Machine  
 Vacuum Veneer Press  
 Other \_\_\_\_\_
- How many of your woodworking machines are Grizzly? \_\_\_\_\_
- Which benchtop tools do you own? Check all that apply.  
 1"x42" Belt Sander  6" - 8" Grinder  
 5" - 8" Drill Press  Mini Lathe  
 8" Table Saw  8" - 10" Bandsaw  
 Scroll Saw  Disc/Belt Sander  
 Spindle/Belt Sander  Mini Jointer  
 10"-12"Thickness Planer  
 Other \_\_\_\_\_
- How many of the machines checked above are Grizzly? \_\_\_\_\_
- Which portable/hand held power tools do you own?  
Check all that apply.  
 Belt Sander  Orbital Sander  
 Biscuit Joiner  Palm Sander  
 Circular Saw  Portable Planer  
 Detail Sander  Saber Saw  
 Drill/Driver  Reciprocating Saw  
 Miter Saw  Router  
 Other \_\_\_\_\_
- What machines/supplies would you like Grizzly Industrial to carry?  
 12" Table Saw  Radial Arm Saw  
 12" Jointer  Panel Saw  
 Brass Hardware  Lumber  
 Paint & Finishing Supplies  
 Contractor's Supplies  
 Combination Planer/Jointer  
 Other \_\_\_\_\_
- What new accessories would you like Grizzly Industrial to carry?  
 Builders Hardware  Hand Tools  
 Fasteners  
 Wood Components  
 Other \_\_\_\_\_
- What other companies do you purchase your tools and supplies from?  
\_\_\_\_\_  
\_\_\_\_\_  
\_\_\_\_\_
- Do you think your purchase represents good value?  
 Yes  No
- Would you recommend Grizzly to a friend?  
 Yes  No
- Would you allow us to use your name as a reference for Grizzly customers in your area? **Note: We never use names more than three times.**  
 Yes  No
- Comments: \_\_\_\_\_  
\_\_\_\_\_  
\_\_\_\_\_

Send a Grizzly Catalog to a friend:

Name_____
Street_____
City_____State_____Zip_____

FOLD ALONG DOTTED LINE

---

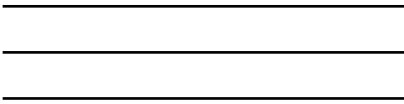

**GRIZZLY INDUSTRIAL, INC.**  
**P.O. BOX 2069**  
**BELLINGHAM, WA 98227-2069**

TAPE ALONG EDGES--PLEASE DO NOT STAPLE

# NOTES

---

---

# WARRANTY AND RETURNS

---

Grizzly Industrial, Inc. warrants every product it sells for a period of **1 year** to the original purchaser from the date of purchase. This warranty does not apply to defects due directly or indirectly to misuse, abuse, negligence, accidents, repairs or alterations or lack of maintenance. This is Grizzly's sole written warranty and any and all warranties that may be implied by law, including any merchantability or fitness, for any particular purpose, are hereby limited to the duration of this written warranty. We do not warrant or represent that the merchandise complies with the provisions of any law or acts unless the manufacturer so warrants. In no event shall Grizzly's liability under this warranty exceed the purchase price paid for the product and any legal actions brought against Grizzly shall be tried in the State of Washington, County of Whatcom.

We shall in no event be liable for death, injuries to persons or property or for incidental, contingent, special, or consequential damages arising from the use of our products.

To take advantage of this warranty, contact us by mail or phone and give us all the details. We will then issue you a "Return Number", which must be clearly posted on the outside as well as the inside of the carton. We will not accept any item back without this number. Proof of purchase must accompany the merchandise.

The manufacturers reserve the right to change specifications at any time because they constantly strive to achieve better quality equipment. We make every effort to ensure that our products meet high quality and durability standards and we hope you never need to use this warranty.

Please feel free to write or call us if you have any questions about the machine or the manual.

Grizzly Industrial, Inc.  
1203 Lycoming Mall Circle  
Muncy, PA 17756  
Phone: (570) 546-9663  
Fax: (800) 438-5901

E-Mail:  
techsupport@grizzly.com

Web Site: <http://www.grizzly.com>

Thank you again for your business and continued support. We hope to serve you again soon.